

**Testing MOST® 150:  
Migration from MOST 25 / 50  
and new Challenges**

**MOST Interconnectivity, Seoul**

November, 18<sup>th</sup> 2010

## Agenda

- 1) New features in MOST 150 at a glance
- 2) Migrating Systems Integration
- 3) New Challenges
- 4) Conclusion

# New features in MOST 150

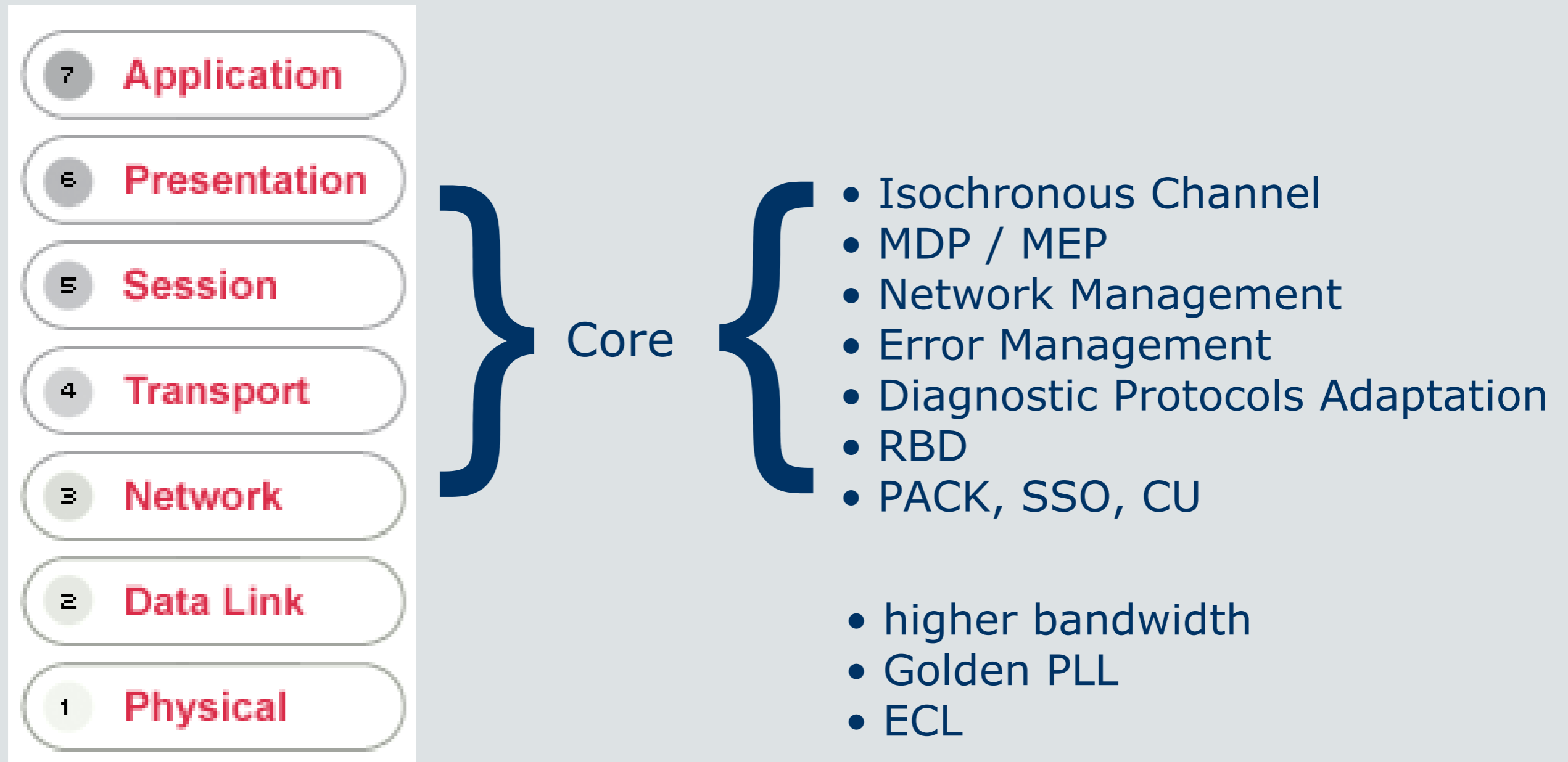

## Agenda

- 1) New features in MOST 150 at a glance
- 2) Migrating Systems Integration
- 3) New Challenges
- 4) Conclusion

## Eye Diagram Measurement:

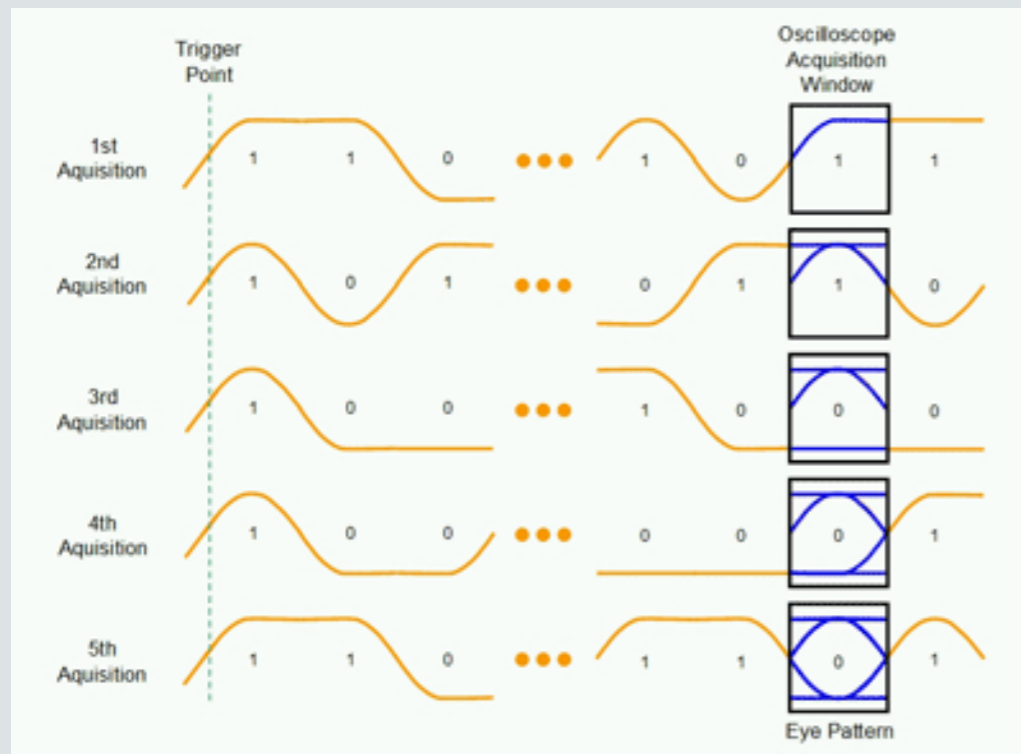

[www.iec.org](http://www.iec.org)

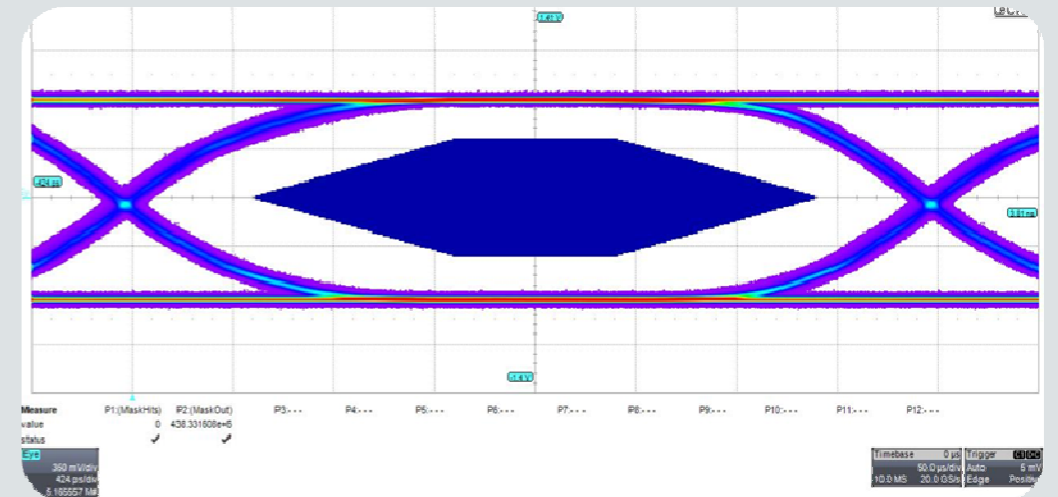

## Unique Test Setups:

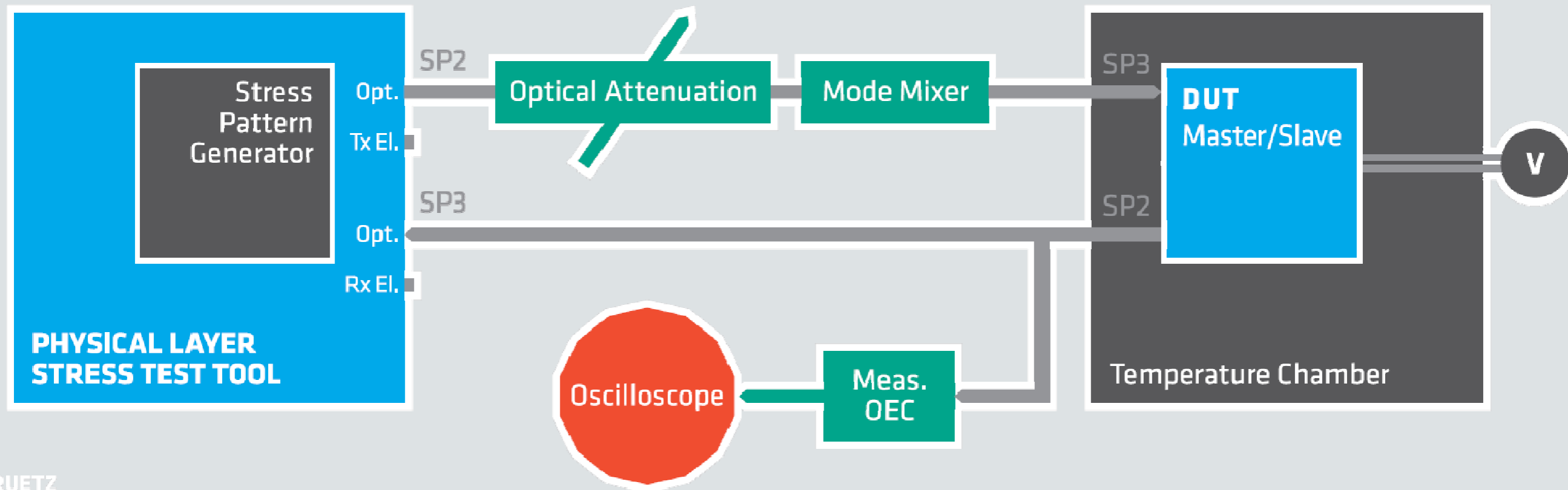

RUETZ  
SYSTEM SOLUTIONS

## Physical Layer Stress Test Tool



Also refer to:

“Use of the MOST150 Physical Layer Stress Test Tool in Development and Production”

[http://mostcooperation.com/news\\_and\\_events/events\\_archive/articles/180183/index.html?do=download&id=180783](http://mostcooperation.com/news_and_events/events_archive/articles/180183/index.html?do=download&id=180783)

## History

1997 1999 2001 2003 2005 2007 2009

OEM specific solution(s) MOST 25 oPhy

Compliance Testing

MOST 50 ePhy

MOST 150

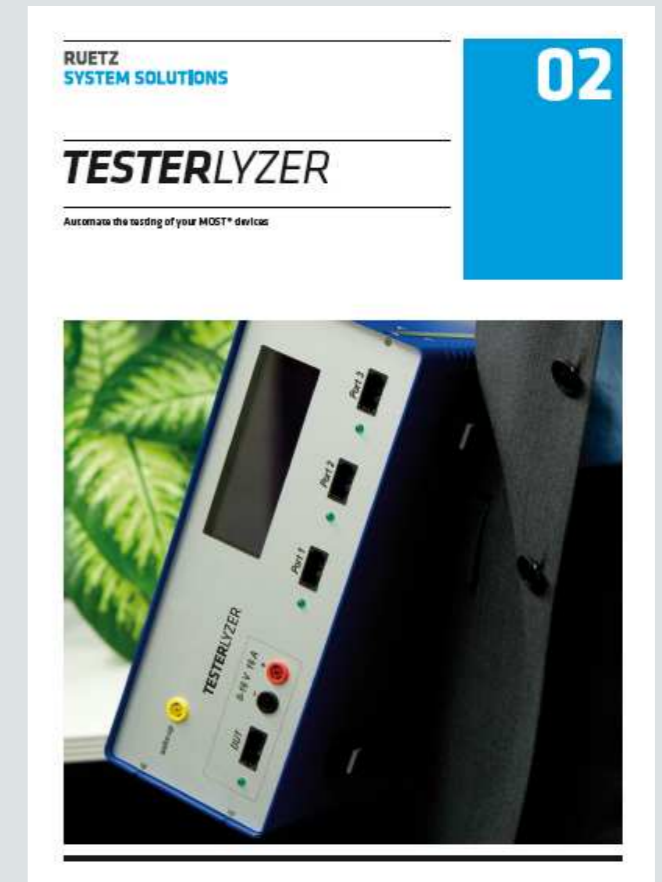

- Based on MOST Expertise since the very beginning
- Contains deep testing know-how
- Made for Compliance Verification plus OEM Add- ons
- Future proof

## TESTERLYZER Tool Migration:

### Platform:

- Drivers updated from OptoLyzer V5 to OptoLyzer G2
- New: ECL box
- Using now standard Laboratory Power Supply
- Cost reduction of 35% compare to MOST50

### Testcases:

- new: SSO / CU
- modified: RBD, Timers
- obsolete: Source Connect

### Benefits:

- Cost effective solution
- Bundled experience of 14 years of Core Testing
- Speed grade independent

## Test Suite MOST High Protocol

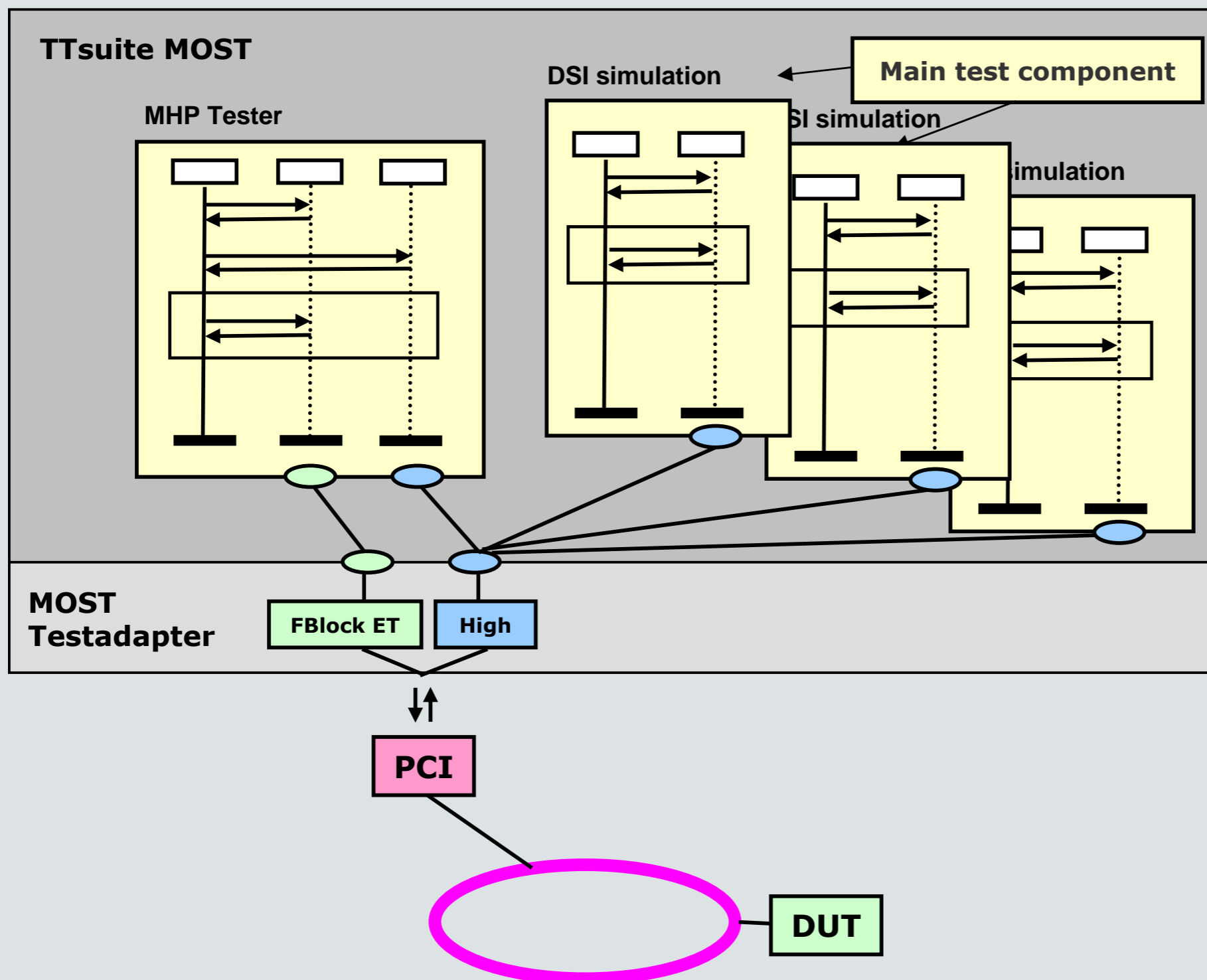

## Network Stress Test Cases

- Uses SMSC's MOST Socket API
- full control of:  
INIC, SypNIC, StressNIC
- for all speed grades
- MDP and MEP support
- examples:
  - accurate measurements (e.g. unlocks)
  - system scan sequence verification

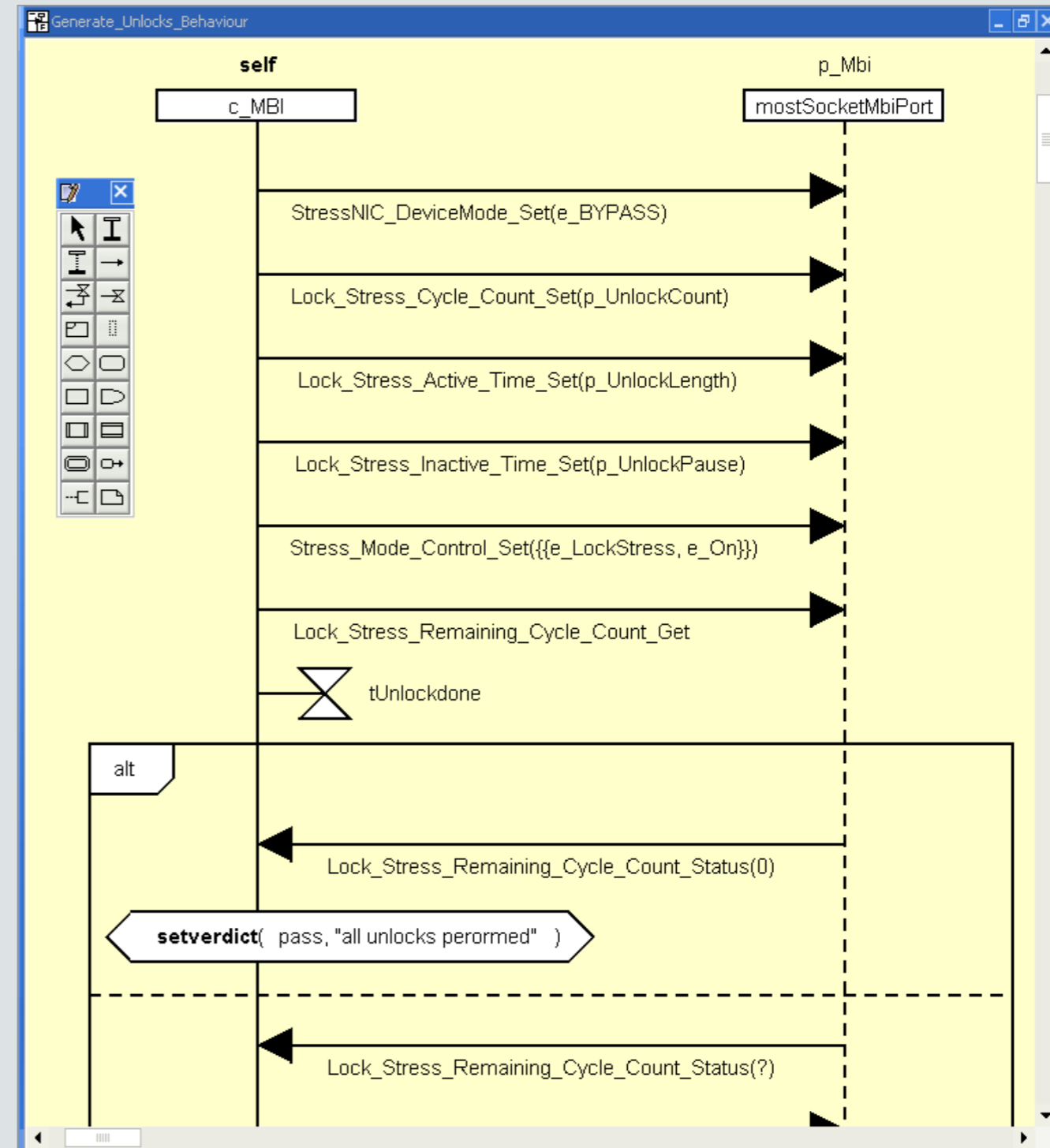

## Example: Test Suite AUXIN

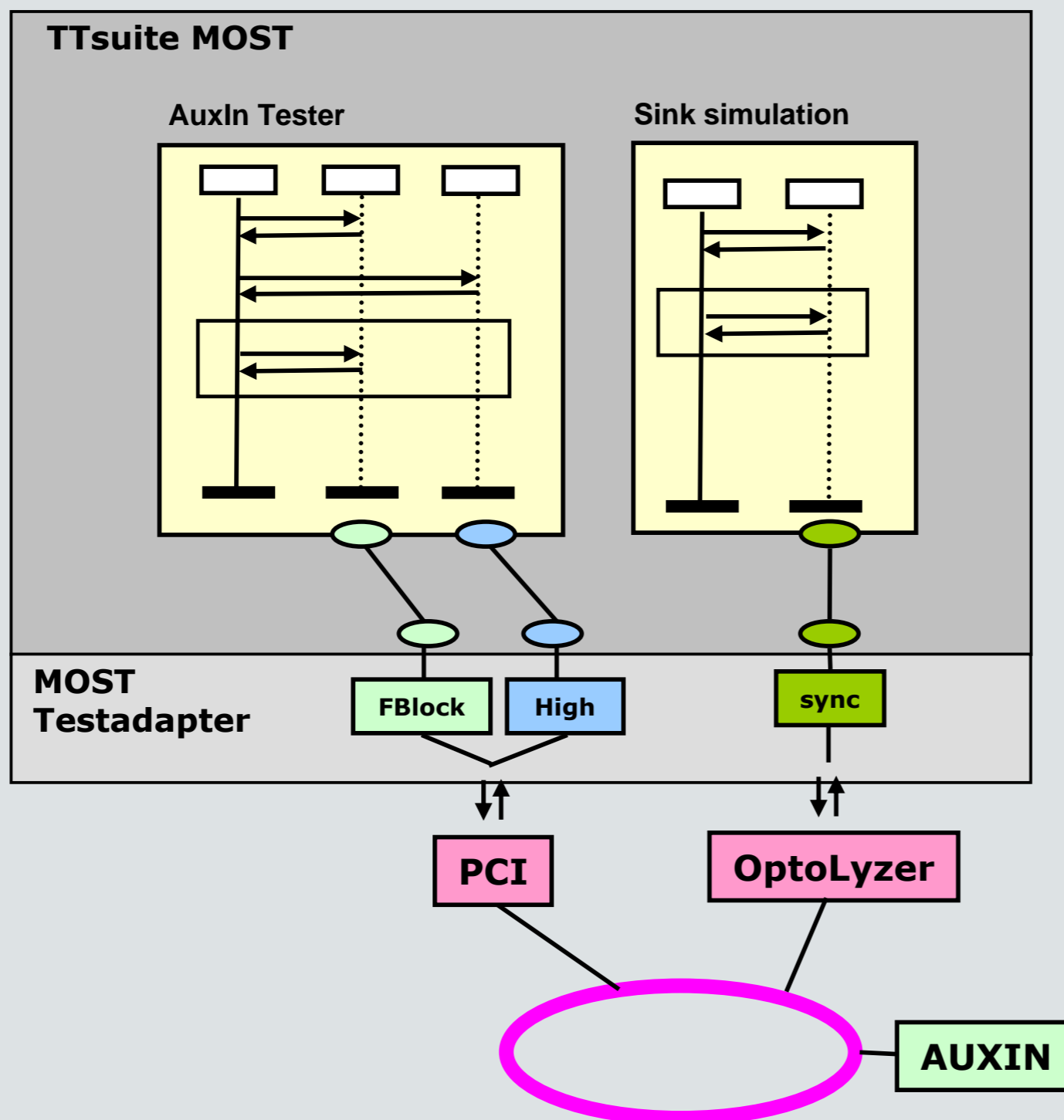

## Agenda

- 1) New features in MOST 150 at a glance
- 2) Migrating Systems Integration
- 3) **New Challenges**
- 4) Conclusion

## Future Scenarios?

- HQ Video Streaming
- CE Integration
- Apps
- Cloud Computing
- Driver Assistance
- Car Remote Control

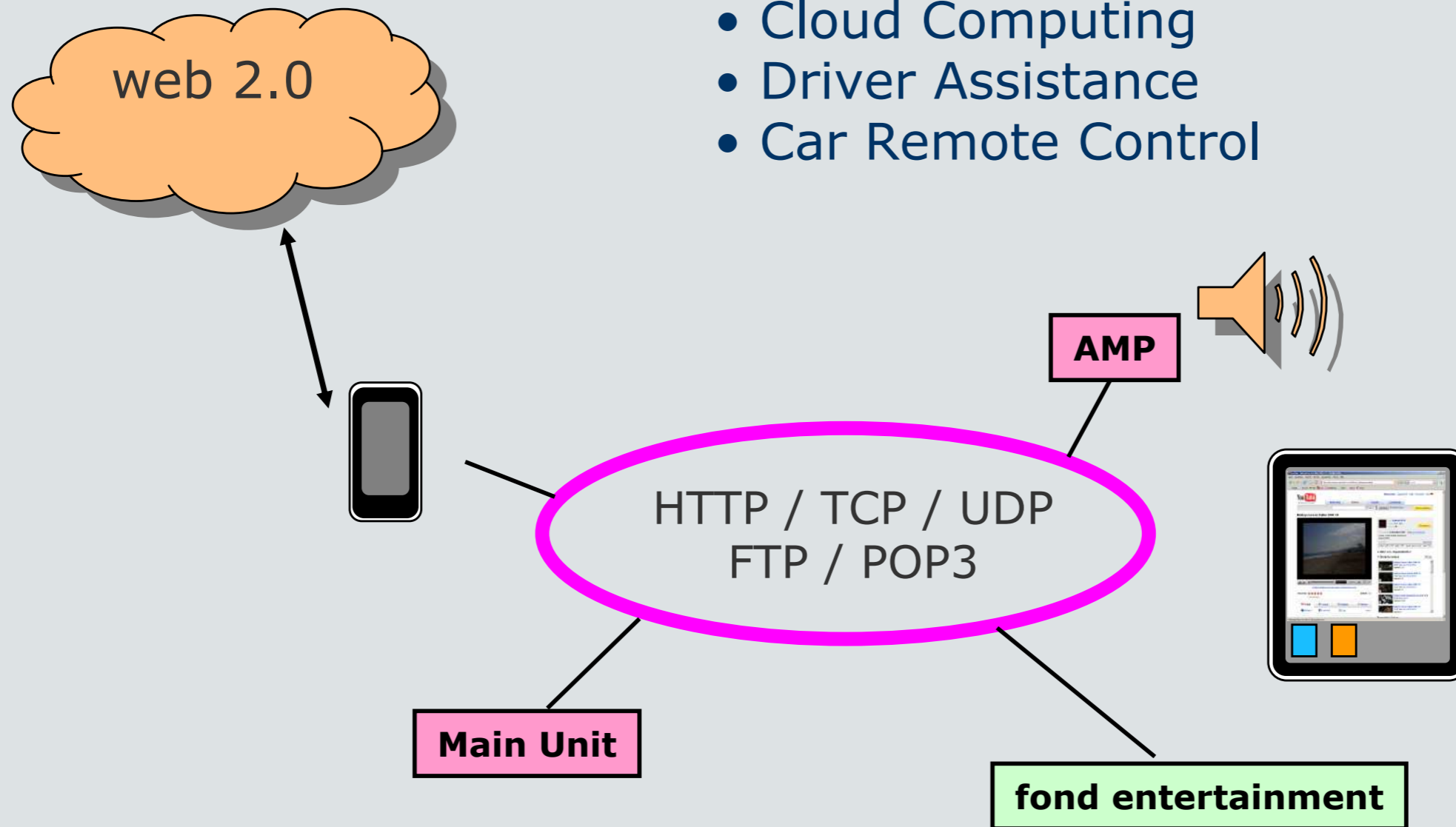

# Example: Testing Internet Clients

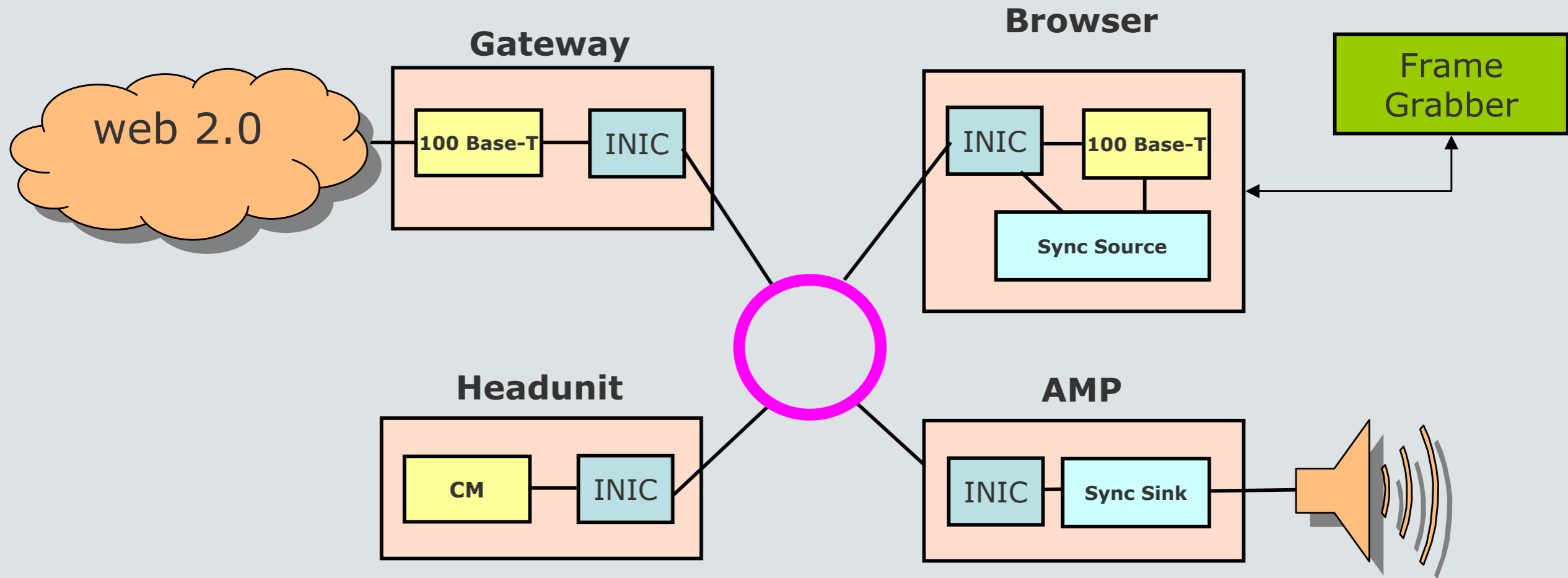

### Example: Internet Client Test Suite

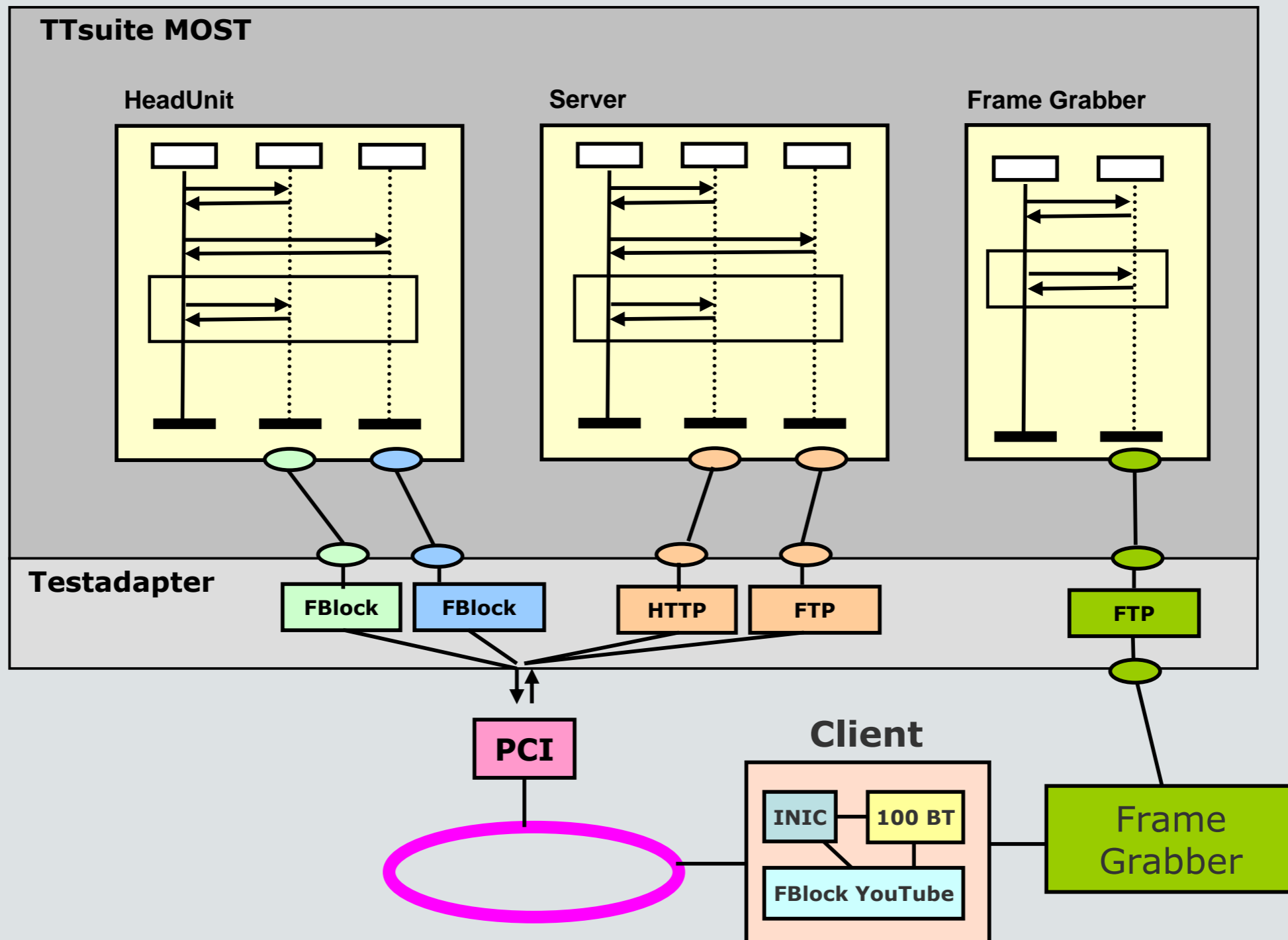

We are ready to test this new challenges by supporting today:

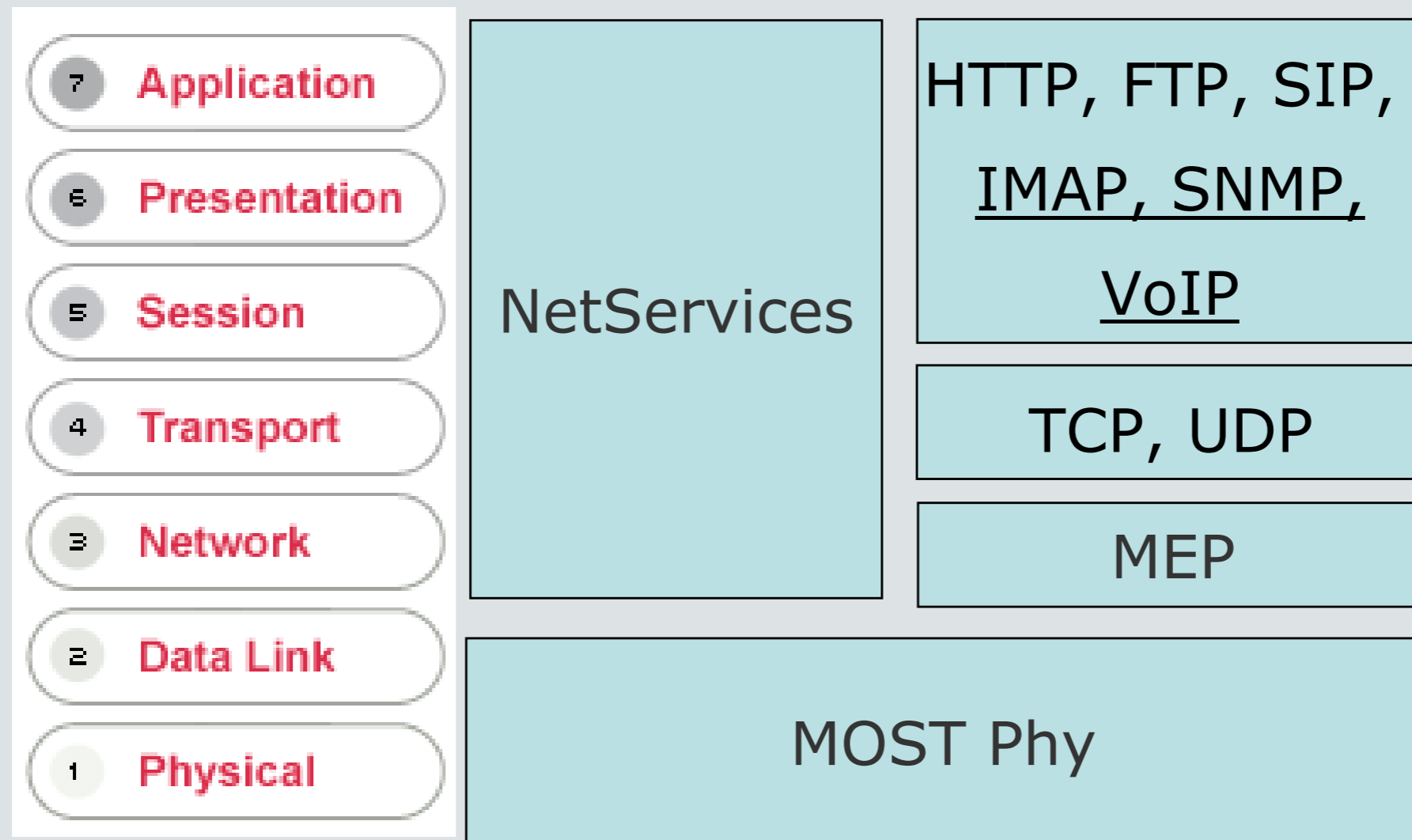

## Agenda

- 1) New features in MOST 150 at a glance
- 2) Migrating Systems Integration
- 3) New Challenges
- 4) Conclusion

## Conclusion

### Migration from MOST 25:

- has been performed by reusing almost everything before
- Physical Layer testing has been made more unique by inventing the Physical Layer Stress Test Tool

### RUETZ SYSTEM SOLUTIONS:

- is a independant Test House
- provides all Tools and Services to perform Systems Integration
- provides TestLabs for OEMs, Suppliers and System Integrators

Korean Partner:

CAN Systems

## Please visit us on our booth



Professional Engineering Services

Test and Simulation Systems

MOST Compliance Test House

Training and Workshops

Thank you for your attention!

**Georg Janker** Geschäftsführer / CTO

**RUETZ**  
**SYSTEM SOLUTIONS**

**Wolfgang Malek** Geschäftsführer / CEO

**RUETZ**  
**SYSTEM SOLUTIONS**